

PRODUCT NO.	MATERIAL
68106-XXXLF	PLAIN NORYL, COLOR: BLACK UL94V-1
68106-XXXHLF	Zytel: FR-50, BLACK UL94V-0

P/N	No. of POS	A	B	C	D
68106-003LF,-003HLF	8	5.08/.200	10.27/.404	12.27/.483	13.84/.545
68106-002LF,-002HLF	6	2.54/.100	7.73/.304	9.73/.383	11.30/.445
68106-001LF,-001HLF	4	0/.0	5.19/.204	7.19/.287	8.76/.345

NOTE

1. PUT DD MARK IN THIS PLACE WITH 0.02/.008 HEIGHT
2. PUT CAV NO. 1.2.3.4. IN THIS PLACE WITH 0.02/.008 HEIGHT
3. THIS PRODUCT MEETS EUROPEAN UNION DIRECTIVES AND OTHER COUNTRY REGULATIONS AS DESCRIBED IN GS-22-008.
4. THIS PRODUCT IS NOT INTENDED TO BE EXPOSED TO A MANUFACTURING SOLDER PROCESS.

注記

1. この位置に DDマークを彫刻、
浮き出し高さ 0.02MAX.
2. この位置に CAV No. 1.2.3.4を彫刻
浮き出し高さ 0.02 MAX.
3. 本製品は、GS-22-008に記載された
ヨーロッパ連合指令と他国の規制に適合しています。
4. 本製品は、はんだ付け工程には使用できません。

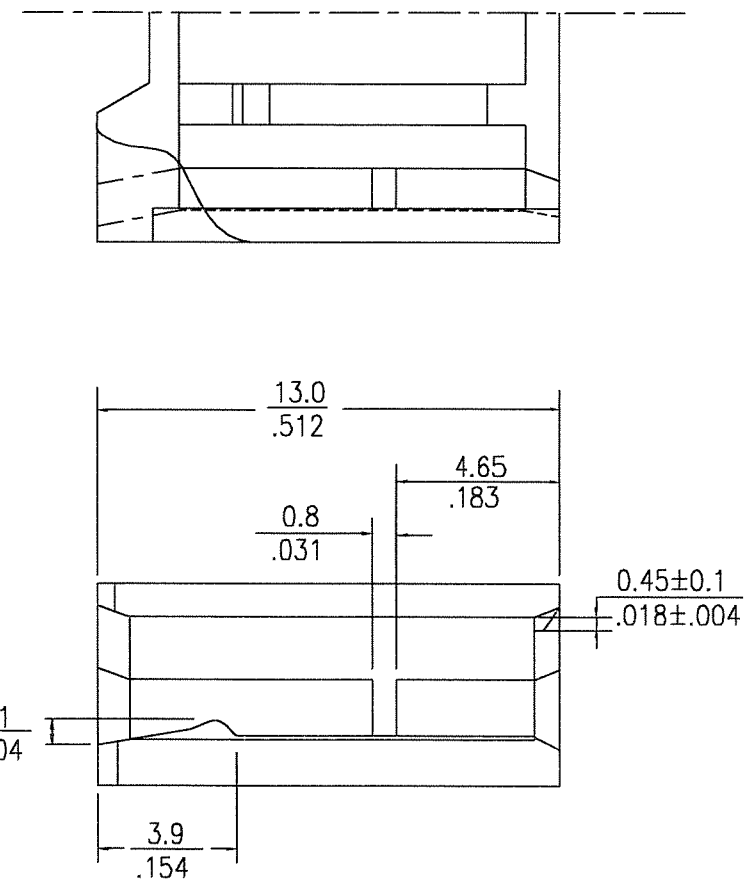
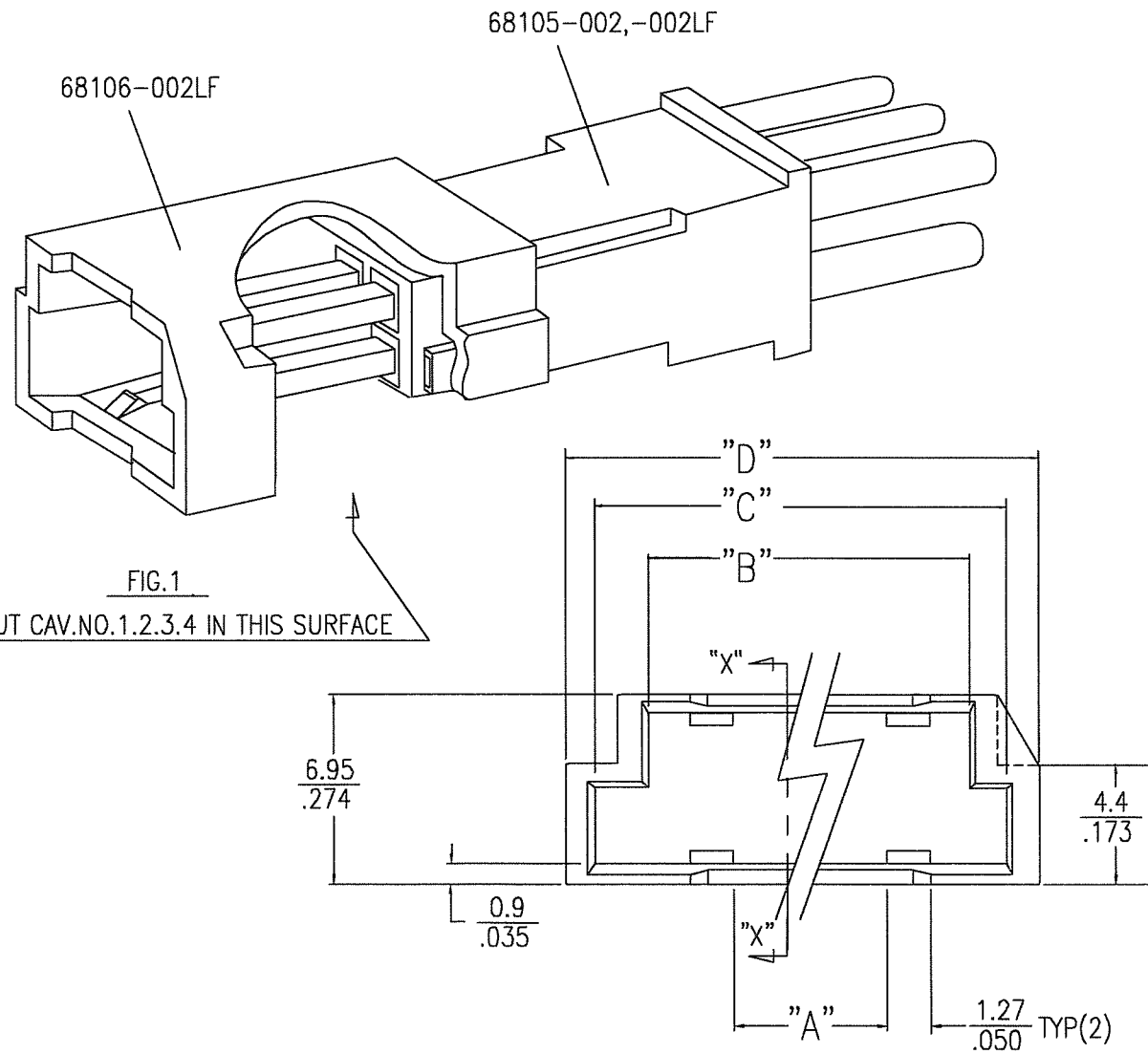

SECT "X"-"X"

mat'l. code				surface		tolerance		projection		product family		CODE
---				ISO 1302 ✓		ISO 406		mm/INCH		5NGF - PV HOUSINGS		JP
itr				description		ecn no		date		title		
A	RELEASED			J8110	NY	11/10/83	0.X	±0.25	POLARIZED M/L HSG SHROUD			
B	REVISED			J8481	NY	12/5/84	0.XX	±0.25	DOUBLE ROW			
C	REVISED			J8481	NY	8/5/87	0.XXX	±0.25	scale 1:1			
D	ADD NEW P/N			J03-0441	YK	10/29/03	R.SHOUJI 9/5/06		dwg no		sheet 1 of 1 size	
E	REVISED			J05-0575	R.S	9/7/05	R.SHOUJI 10/2/06		68106		A3	
F	REVISED			J06-0370	R.S	10/2/06	chr		type		PRODUCT CUSTOMER Drawing	
sheet		revision		F						Rev.		
index		sheet		1						F		

FCI CONFIDENTIAL



This document is the property of and embodies CONFIDENTIAL and PROPRIETARY information of FCI. No part of this information shall be disclosed, copied, or used in any way or disclosed to others without the written consent of FCI. Copyright FCI.